

A7A Single and Dual Modular Automatic Airless Spray Guns

Customer Product Manual
Part 1072609A
Issued 8/06

**For parts and technical support, call the Industrial Coating
Systems Customer Support Center at (800) 433-9319 or
contact your local Nordson representative.**

This document is subject to change without notice.
Check <http://emanuals.nordson.com> for the latest version.



NORDSON CORPORATION • AMHERST, OHIO • USA

Table of Contents

Safety	1	Maintenance	7
Qualified Personnel	1	Troubleshooting	7
Intended Use	1	Single Gun Repair	8
Regulations and Approvals	1	Disassembly	8
Personal Safety	1	Cleaning and Inspection	8
High-Pressure Fluids	2	Assembly	8
Fire Safety	2	Dual Gun Repair	10
Halogenated Hydrocarbon Solvent Hazards ..	3	Disassembly	10
Action in the Event of a Malfunction	3	Cleaning and Inspection	10
Disposal	3	Assembly	10
Description	4	Parts	12
Nozzles	4	Single Gun Parts	12
Specifications	4	Dual Gun Parts	14
Gun Module Components and Operation	5	Options	16
Installation	6	Service Kits	16
Mounting	6	Service Parts	16
Fluid Connections	6		
Trigger Air Connection	6		
Nozzle Installation	7		

Contact Us

Nordson Corporation welcomes requests for information, comments, and inquiries about its products. General information about Nordson can be found on the Internet using the following address:

<http://www.nordson.com>.

Address all correspondence to:

Nordson Corporation
Attn: Customer Service
555 Jackson Street
Amherst, OH 44001

Notice

This is a Nordson Corporation publication which is protected by copyright. Original copyright date 2005. No part of this document may be photocopied, reproduced, or translated to another language without the prior written consent of Nordson Corporation. The information contained in this publication is subject to change without notice.

Trademarks

Nordson and the Nordson logo are registered trademarks of Nordson Corporation.

Viton is a registered trademark of DuPont Dow Elastomers. L.L.C.

A7A Modular Automatic Airless Spray Gun

Safety

Read and follow these safety instructions. Task- and equipment-specific warnings, cautions, and instructions are included in equipment documentation where appropriate.

Make sure all equipment documentation, including these instructions, is accessible to persons operating or servicing equipment.

Qualified Personnel

Equipment owners are responsible for making sure that Nordson equipment is installed, operated, and serviced by qualified personnel. Qualified personnel are those employees or contractors who are trained to safely perform their assigned tasks. They are familiar with all relevant safety rules and regulations and are physically capable of performing their assigned tasks.

Intended Use

Use of Nordson equipment in ways other than those described in the documentation supplied with the equipment may result in injury to persons or damage to property.

Some examples of unintended use of equipment include

- using incompatible materials
- making unauthorized modifications
- removing or bypassing safety guards or interlocks
- using incompatible or damaged parts
- using unapproved auxiliary equipment
- operating equipment in excess of maximum ratings

Regulations and Approvals

Make sure all equipment is rated and approved for the environment in which it is used. Any approvals obtained for Nordson equipment will be voided if instructions for installation, operation, and service are not followed.

Personal Safety

To prevent injury follow these instructions.

- Do not operate or service equipment unless you are qualified.
- Do not operate equipment unless safety guards, doors, or covers are intact and automatic interlocks are operating properly. Do not bypass or disarm any safety devices.
- Keep clear of moving equipment. Before adjusting or servicing moving equipment, shut off the power supply and wait until the equipment comes to a complete stop. Lock out power and secure the equipment to prevent unexpected movement.
- Relieve (bleed off) hydraulic and pneumatic pressure before adjusting or servicing pressurized systems or components. Disconnect, lock out, and tag switches before servicing electrical equipment.
- While operating manual spray guns, make sure you are grounded. Wear electrically conductive gloves or a grounding strap connected to the gun handle or other true earth ground. Do not wear or carry metallic objects such as jewelry or tools.
- If you receive even a slight electrical shock, shut down all electrical or electrostatic equipment immediately. Do not restart the equipment until the problem has been identified and corrected.

Personal Safety (contd)

- Obtain and read Material Safety Data Sheets (MSDS) for all materials used. Follow the manufacturer's instructions for safe handling and use of materials, and use recommended personal protection devices.
- Make sure the spray area is adequately ventilated.
- To prevent injury, be aware of less-obvious dangers in the workplace that often cannot be completely eliminated, such as hot surfaces, sharp edges, energized electrical circuits, and moving parts that cannot be enclosed or otherwise guarded for practical reasons.

High-Pressure Fluids

High-pressure fluids, unless they are safely contained, are extremely hazardous. Always relieve fluid pressure before adjusting or servicing high pressure equipment. A jet of high-pressure fluid can cut like a knife and cause serious bodily injury, amputation, or death. Fluids penetrating the skin can also cause toxic poisoning.

If you suffer a fluid injection injury, seek medical care immediately. If possible, provide a copy of the MSDS for the injected fluid to the health care provider.

The National Spray Equipment Manufacturers Association has created a wallet card that you should carry when you are operating high-pressure spray equipment. These cards are supplied with your equipment. The following is the text of this card:



WARNING: Any injury caused by high pressure liquid can be serious. If you are injured or even suspect an injury:

- Go to an emergency room immediately.
- Tell the doctor that you suspect an injection injury.
- Show him this card
- Tell him what kind of material you were spraying

MEDICAL ALERT—AIRLESS SPRAY WOUNDS: NOTE TO PHYSICIAN

Injection in the skin is a serious traumatic injury. It is important to treat the injury surgically as soon as possible. Do not delay treatment to research toxicity. Toxicity is a concern with some exotic coatings injected directly into the bloodstream.

Consultation with a plastic surgeon or a reconstructive hand surgeon may be advisable.

The seriousness of the wound depends on where the injury is on the body, whether the substance hit something on its way in and deflected causing more damage, and many other variables including skin microflora residing in the paint or gun which are blasted into the wound. If the injected paint contains acrylic latex and titanium dioxide that damage the tissue's resistance to infection, bacterial growth will flourish. The treatment that doctors recommend for an injection injury to the hand includes immediate decompression of the closed vascular compartments of the hand to release the underlying tissue distended by the injected paint, judicious wound debridement, and immediate antibiotic treatment.

Fire Safety

To avoid a fire or explosion, follow these instructions.

- Ground all conductive equipment. Use only grounded air and fluid hoses. Check equipment and workpiece grounding devices regularly. Resistance to ground must not exceed one megohm.
- Shut down all equipment immediately if you notice static sparking or arcing. Do not restart the equipment until the cause has been identified and corrected.
- Do not smoke, weld, grind, or use open flames where flammable materials are being used or stored.
- Do not heat materials to temperatures above those recommended by the manufacturer. Make sure heat monitoring and limiting devices are working properly.

- Provide adequate ventilation to prevent dangerous concentrations of volatile particles or vapors. Refer to local codes or your material MSDS for guidance.
- Do not disconnect live electrical circuits when working with flammable materials. Shut off power at a disconnect switch first to prevent sparking.
- Know where emergency stop buttons, shutoff valves, and fire extinguishers are located. If a fire starts in a spray booth, immediately shut off the spray system and exhaust fans.
- Shut off electrostatic power and ground the charging system before adjusting, cleaning, or repairing electrostatic equipment.
- Clean, maintain, test, and repair equipment according to the instructions in your equipment documentation.
- Use only replacement parts that are designed for use with original equipment. Contact your Nordson representative for parts information and advice.

Halogenated Hydrocarbon Solvent Hazards

Do not use halogenated hydrocarbon solvents in a pressurized system that contains aluminum components. Under pressure, these solvents can react with aluminum and explode, causing injury, death, or property damage. Halogenated hydrocarbon solvents contain one or more of the following elements:

<u>Element</u>	<u>Symbol</u>	<u>Prefix</u>
Fluorine	F	“Fluoro-”
Chlorine	Cl	“Chloro-”
Bromine	Br	“Bromo-”
Iodine	I	“Iodo-”

Check your material MSDS or contact your material supplier for more information. If you must use halogenated hydrocarbon solvents, contact your Nordson representative for information about compatible Nordson components.

Action in the Event of a Malfunction

If a system or any equipment in a system malfunctions, shut off the system immediately and perform the following steps:

- Disconnect and lock out system electrical power. Close hydraulic and pneumatic shutoff valves and relieve pressures.
- Identify the reason for the malfunction and correct it before restarting the system.

Disposal

Dispose of equipment and materials used in operation and servicing according to local codes.

Description

The A7A single and dual modular automatic spray guns are high-cycle, air-operated, airless spray guns. They can be used for general finishing as well as ultra-high speed applications using solventborne or waterborne coatings.

Nozzles

Nozzles are not included with the spray guns. For information on Nordson airless nozzles and help in choosing the correct nozzle for your application, contact your Nordson representative.

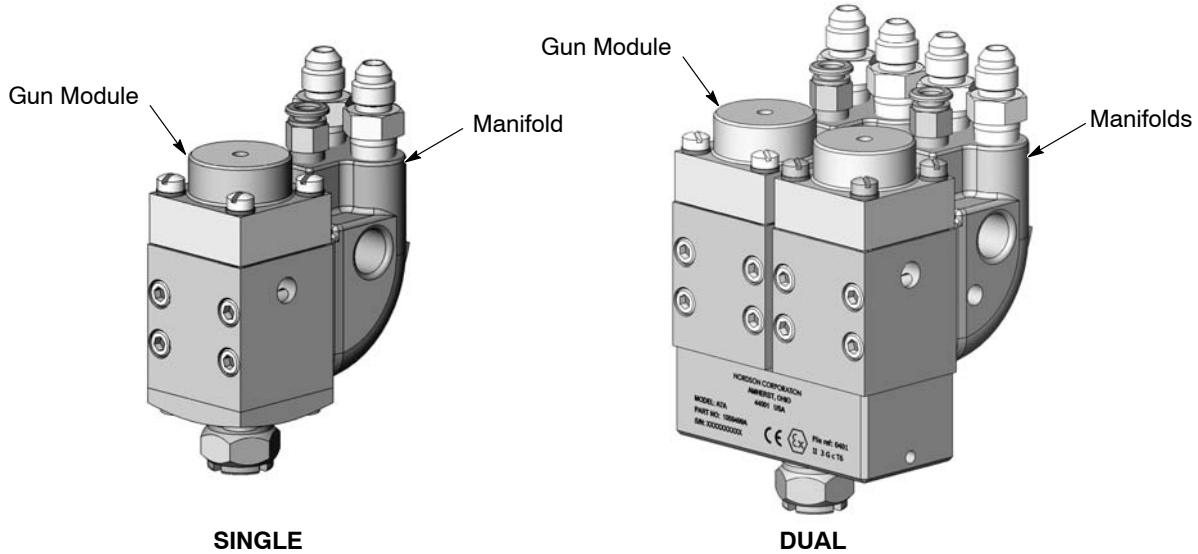

Figure 1 A7A Modular Spray Guns

Specifications

Properties	Specification
Maximum Fluid Pressure	207 bar (3000 psi)
Air Trigger Requirements	2.75–8.27 bar (40–120 psi)
Single Gun	
Length:	89 mm (3.5 in.)
Width:	38.1 mm (1.5 in.)
Height:	73.2 mm (2.88 in.)
Weight:	0.86 kg (1.9 lb)
Dual Gun	
Length:	108 mm (4.25 in.)
Width:	77.7 mm (3.06 in.)
Height:	73.2 mm (2.88 in.)
Weight:	2.31 kg (5.1 lb)
Fittings	
Fluid Supply and Return	1/2–20 JIC x 1/4-in. NPT
Trigger Air	1/4-in. tubing x 1/8-in. NPT
Mounting	13-mm (1/2-in.) round bar

Gun Module Components and Operation

The spray guns consist of a fluid/air/mounting manifold and a gun module. This sectional view shows the main components of the gun modules.

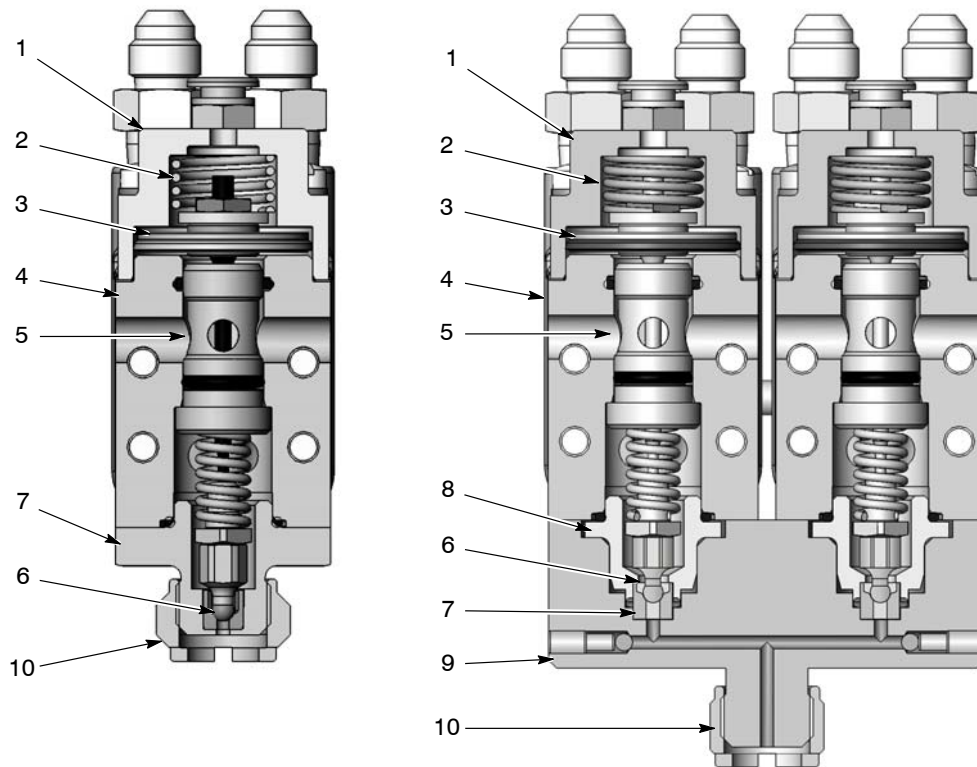

Figure 2 A7A Modular Spray Guns

- | | | |
|-----------------------|----------------------|------------------|
| 1. Air cylinder | 5. Packing cartridge | 8. Seat retainer |
| 2. Compression spring | 6. Ball tip | 9. Manifold |
| 3. Piston assembly | 7. Seat | 10. Nozzle nut |
| 4. Gun body | | |

The packing cartridge stem connects the piston to the ball tip. When the gun is triggered on, air pressure pushes against the bottom of the piston, lifting the ball tip away from the seat and allowing coating material to flow through the seat and nozzle.

When the gun is triggered off, the air pressure forcing the piston up is released. The compression spring and packing cartridge spring force the ball tip against the seat, stopping the flow of coating material out of the nozzle.

The packing cartridge seals prevent coating material from entering the air cylinder. If the packing cartridge seals start to leak, coating material will flow out the weep holes in the gun body.

Installation



WARNING: Allow only qualified personnel to perform the following tasks. Follow the safety instructions in this document and all other related documentation.



WARNING: Ground all electrically conductive equipment in the system. Use only grounded fluid and air hoses.

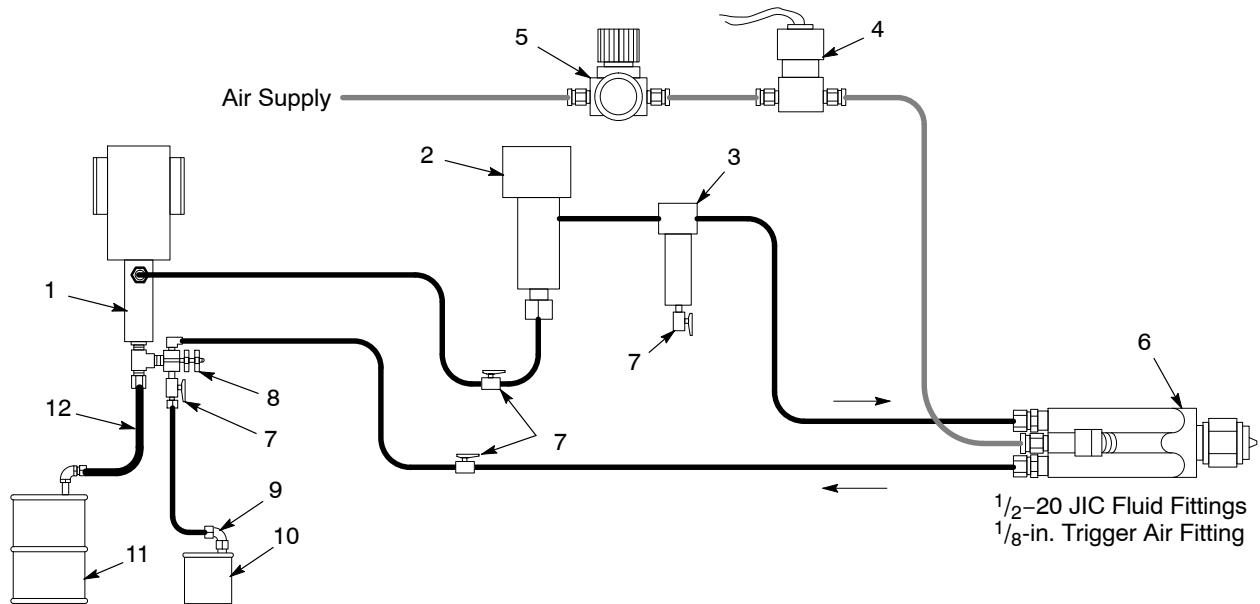

Figure 3 Typical Circulating System

- | | | |
|-------------------|----------------------|-------------------------|
| 1. Pump | 5. Air regulator | 9. Drain off rod |
| 2. Heater | 6. A7A gun | 10. Waste container |
| 3. Filter | 7. Ball valves | 11. Coating supply |
| 4. Solenoid valve | 8. Circulation valve | 12. Siphon hose and rod |

Mounting

Slide a 13-mm ($1/2$ -in.) round mounting bar through the hole in the manifold, orient the gun as desired, and tighten the square head screw.

Fluid fittings have $1/2$ -20 JIC threads. Connect the fluid supply and return hoses to the fittings. Either fitting can be used for supply or return.

Fluid Connections



WARNING: In the fluid supply line, install an approved pressure relief device set to the lowest maximum working pressure of all system components. The fluid hoses must have a minimum burst pressure greater than the pressure relief device setting.

Trigger Air Connection

Connect $1/8$ -inch tubing from a solenoid valve to the trigger air fitting on the manifold.

For applications faster than 600 cycles per minute, install the optional quick-exhaust valve at the air inlet. To do this, remove the air fitting and install a $1/4$ -in. NPT nipple in the manifold, then install the quick-exhaust valve on the nipple, and the air fitting in the quick-exhaust valve.

Nozzle Installation

Remove the nozzle nut from the end of the gun. Install your nozzle in the nozzle nut, then screw the nut onto the gun. Tighten the nozzle nut securely.

NOTE: Make sure the nozzle and seat sealing surfaces are clean before installing the nozzle.

Maintenance

Flush the gun periodically to keep it clean and free of contaminants. As required, disassemble and clean the gun and replace any worn parts.

Make sure the trigger air is clean and dry. If you are operating the gun at high cycle rates for long periods of time, install an air lubricator in the air supply line. This will extend the life of the air piston seal.

Troubleshooting



WARNING: Allow only qualified personnel to perform the following tasks. Follow the safety instructions in this document and all other related documentation.

These procedures cover only the most common problems. If you cannot solve the problem with the information given here, contact the Nordson Finishing Customer Support Center at (800) 433-9319 or your local Nordson representative for help.

Problem	Possible Cause	Corrective Action
1. Leaking around nozzle or nozzle retaining nut	Dirty or damaged nozzle or seat sealing surfaces	Tighten the nozzle nut. If the leak persists, relieve system pressure. Remove the nozzle nut and clean the nozzle and seat sealing surfaces. If the leak persists, replace the nozzle or seat (the ball tip and seat are a matched set and must be replaced together).
2. Leaking from weep holes	Worn packing cartridge	Replace the packing cartridge with the appropriate kit. Refer to <i>Parts</i> .
3. Spitting	Dirty or worn ball and seat	Clean or replace the ball and seat.
	Actuating or trigger air lines too long	Mount the solenoid on or as close as possible to the gun.
	Air trapped in fluid system	Purge air from system by opening the drain valve until no air bubbles are seen, or spraying until spitting stops. Make sure the pump is not siphoning air into the fluid system.
4. On/Off cycle response poor or gun not opening or closing	Air piston assembly worn or out of adjustment	Adjust or replace the air piston assembly.
	Low air pressure to the solenoid valve	Increase the air pressure to between 2.7–4.1 bar (40–60 psi).
	Trigger air lines too long	Mount the solenoid on or as close as possible to the gun.
	Fluid pressure too high	Reduce the fluid pressure. The guns will not close if their maximum working pressure is exceeded.

Single Gun Repair



WARNING: Allow only qualified personnel to perform the following tasks. Follow the safety instructions in this document and all other related documentation.



WARNING: Shut off the fluid pump and relieve the system fluid pressure before disconnecting the fluid hoses from the spray gun. High pressure fluid is dangerous and can cause injection injuries.

See Figure 4. If you are using service kit 1056459, to repair the single gun, you need only perform steps 1–4 of the Disassembly procedure, and Steps 2–4 of the Assembly procedure.

Disassembly

1. Flush the spray gun with clean solvent or cleaning solution.
2. Relieve the system fluid and air pressure.
3. Remove the screws (15) and separate the gun module from the manifold (17).
4. Remove the nozzle nut (14) and nozzle.
5. To disassemble the gun module:
 - a. Remove the O-rings (16) from the module.
 - b. Remove the air cylinder (4), gasket (5), and compression spring (6).
 - c. Hold the packing cartridge stem (11) with a wrench and remove the lock nut (7). Unscrew the piston assembly (8) from the stem and separate the seal nut, O-ring and piston (8A, 8B, 8C).
 - d. Remove the screws (13) and seat (12C).
 - e. Push or pull the packing cartridge out of the gun body (10).
 - f. Unscrew the ball tip (12A) from the packing cartridge stem.

Cleaning and Inspection

1. Clean the wetted parts with a compatible cleaning solution.

2. Inspect the ball tip and seat. If either are worn or damaged, replace both. The ball tip and seat are a matched set and only sold as a kit.
3. Inspect the piston seal (8C). If it is worn or damaged replace it.
4. Inspect all gaskets and O-rings. Replace any that are damaged, using the service kit listed in *Parts*.
5. If coating material was leaking from the weep holes in the gun body, replace the packing cartridge.

Assembly

1. To assemble the gun module:
 - a. Install the O-ring (9) in the internal groove in the gun body.
 - b. Apply VC-3 thread-locking compound to the bottom threads of the packing cartridge stem (11).
 - c. Screw the ball tip (12A) onto the packing cartridge stem.
 - d. Push the packing cartridge up into the gun body.
 - e. Install the O-ring (12B) on the seat (12C).
 - f. Install the seat on the gun body and tighten the screws (13) securely.
 - g. Thread the piston assembly (8) onto the packing cartridge stem until it rests against the gun body.
 - h. Thread the lock nut (7) part way down the stem. Turn the piston assembly counterclockwise $1/2$ to $3/4$ turn, until it is 0.016–0.023 inches from the gun body. Thread the lock nut down against the piston assembly.
 - i. Apply a drop of VC-3 thread-locking compound to the lock nut threads. Hold the packing cartridge stem with a small wrench while tightening the lock nut against the piston assembly.
 - j. Install the compression spring (6) on top of the piston.
 - k. Install the gasket and air cylinder. Tighten the screws (2) securely.
2. Install the O-rings (16) in the gun body grooves.

3. Install the nozzle in the nozzle nut (14), then thread the nozzle nut on the seat and tighten it securely.

4. Install the gun module (1) on the manifold (17) and tighten the screws (15) securely.

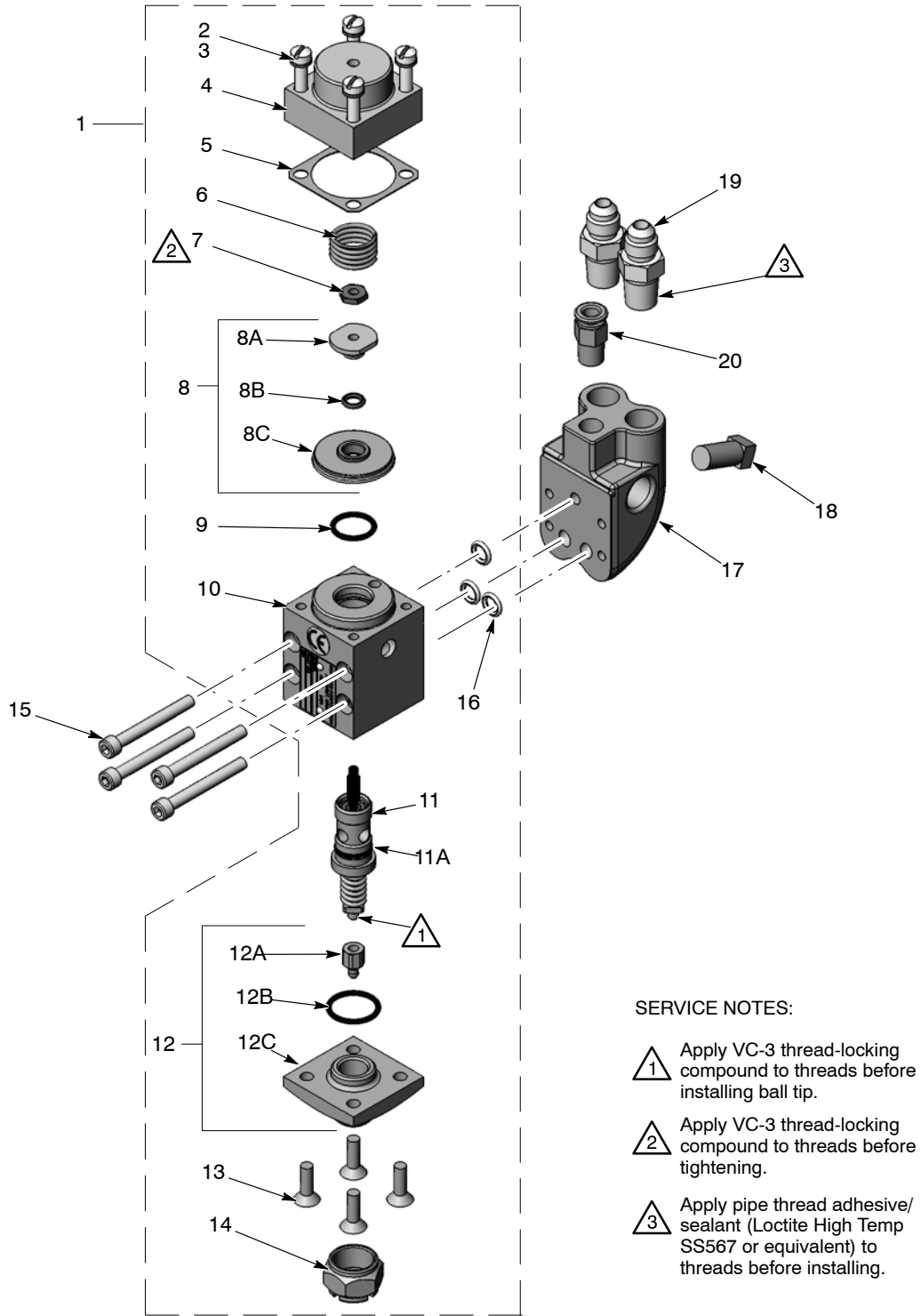

Figure 4 Single Gun Repair

Dual Gun Repair



WARNING: Allow only qualified personnel to perform the following tasks. Follow the safety instructions in this document and all other related documentation.



WARNING: Shut off the fluid pump and relieve the system fluid pressure before disconnecting the gun module from the spray gun. High pressure fluid is dangerous and can cause injection injuries.

See Figure 4. If you are using service kit 1059498, to repair the dual gun, you need only perform steps 1–5 of the Disassembly procedure, and steps 2–4 of the Assembly procedure.

Disassembly

1. Flush the spray gun with clean solvent or cleaning solution.
2. Relieve the system fluid and air pressure.
3. Remove the screws (21). Separate the gun module (1) from the manifolds (23).
4. Remove the O-rings (22) from the gun body grooves (10).
5. Remove the nozzle nut (20) and nozzle.
6. To disassemble each side of the gun module:
 - a. Remove the air cylinder (4), gasket (5), and compression spring (6).
 - b. Hold the packing cartridge stem (11) with a wrench and remove the lock nut (7). Unscrew the piston assembly (8) from the stem and separate the seal nut, O-ring and piston (8A, 8B, 8C).
 - c. Remove the screws (19). Separate the gun body (10) from the manifold (16).
 - d. Push or pull the packing cartridge out of the bodies.
 - e. Unscrew the ball tip (12A) from the packing cartridge stem.
 - f. Remove the large O-ring 13, seat retainer (14), seat (12B), and small O-ring (15) from the manifold.

Cleaning and Inspection

1. Clean the wetted parts with a compatible cleaning solution.
2. The ball tips and seats are matched sets. If either are worn or damaged, replace both.
3. Inspect the piston seal (8C). If it is worn or damaged replace the piston (8).
4. Inspect all gaskets and O-rings. Replace any that are damaged, using the service kit listed in *Parts*.
5. If coating material was leaking from the weep holes in the gun bodies, replace the packing cartridges.

Assembly

1. Assemble each side of the module as follows:
 - a. If removed, install the O-ring (9) in the internal groove in the body (10).
 - b. Apply VC-3 thread-locking compound to the bottom threads of the packing cartridge stem (11).
 - c. Screw the ball tip (12A) onto the packing cartridge stem.
 - d. Push the packing cartridge up into the gun body.
 - e. Install the seat (12B), O-ring (15), and seat retainer (14) in the manifold (16).
 - f. Install the O-ring (13) on the seat retainer.
 - g. Install the body onto the manifold and tighten the screws (19) securely.
 - h. Thread the piston assembly (8) onto the packing cartridge stem until it rests against the gun body.
 - i. Thread the lock nut (7) part way down the stem. Turn the piston assembly counterclockwise $\frac{1}{2}$ to $\frac{3}{4}$ turn, until it is 0.016–0.023 inches from the gun body. Thread the lock nut down against the piston assembly.
 - j. Apply a drop of VC-3 thread-locking compound to the lock nut threads. Hold the packing cartridge stem with a small wrench while tightening the lock nut against the piston assembly.
 - k. Install the compression spring (6) on top of the piston.

1. Install the gasket (5) and air cylinder (4). Install the screws (2) and lockwashers (3) and tighten the screws securely.
2. Install the O-rings (22) into the gun body grooves.
3. Install the nozzle in the nozzle nut (20), then thread the nozzle nut onto the manifold and tighten it securely.
4. Install the module (1) on the manifolds (23) and tighten the screws (21) securely.

SERVICE NOTES:

- 1 Apply VC-3 thread-locking compound to threads before installing ball tip.
- 2 Apply VC-3 thread-locking compound to threads before tightening.
- 3 Apply pipe thread adhesive/sealant (Loctite High Temp SS567 or equivalent) to threads before installing.

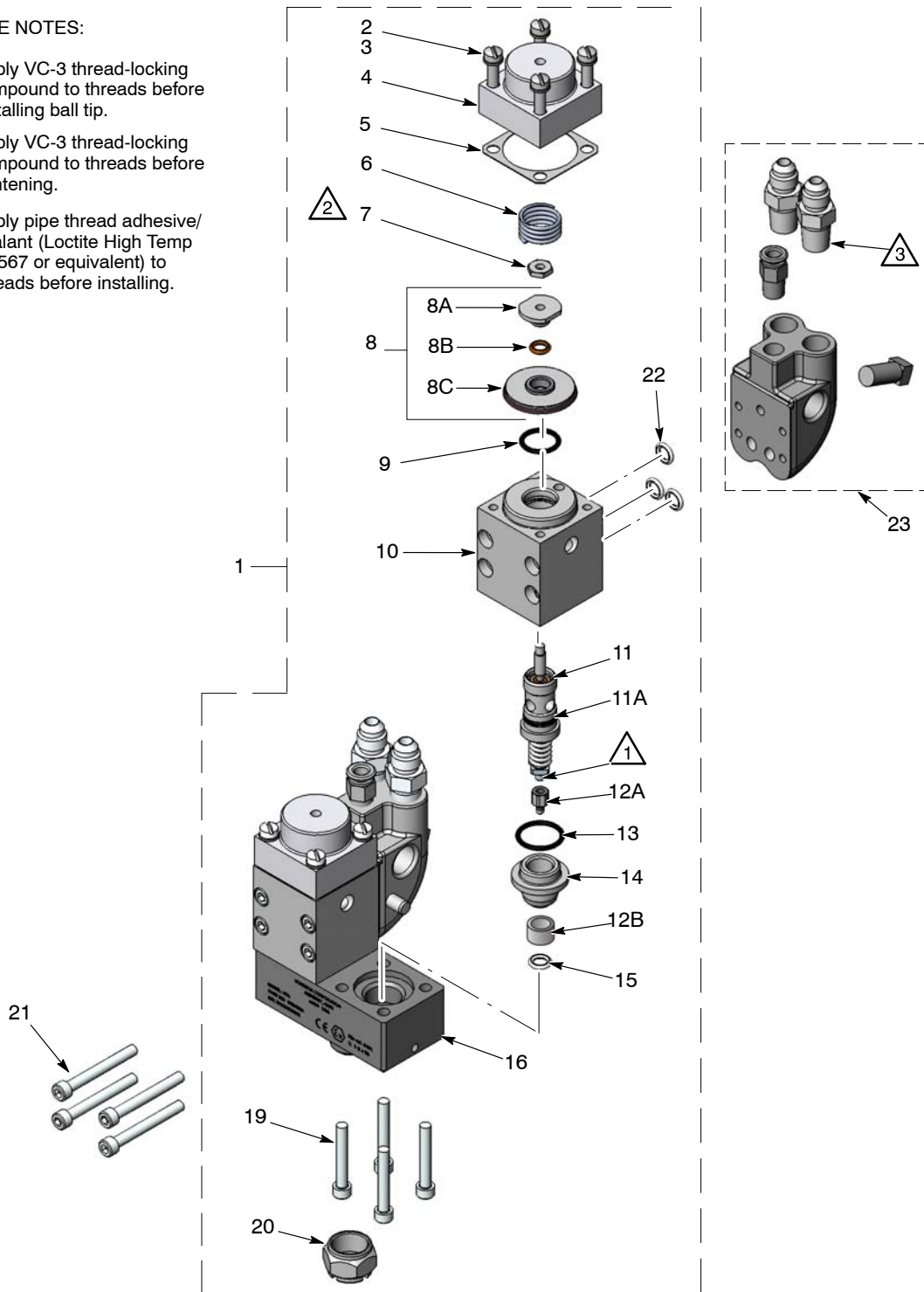

Figure 5 Dual Gun Repair

Parts

To order parts, call the Nordson Finishing Customer Support Center at (800) 433-9319 or contact your local Nordson representative.

Single Gun Parts

See Figure 6.

Item	Part	Description	Quantity	Note
—	1032379	GUN, A7A, stainless steel, LBS, with manifold	1	
1	-----	• MODULE, A7A, stainless steel, Large Ball and Seat	1	A
2	981140	• • SCREW, fillet head, #10–32 x 1.00 in., slotted, zinc	4	A
3	983120	• • WASHER, lock, split, #10, steel, nickel	4	A
4	-----	• • CYLINDER, air	1	A
5	153031	• • GASKET, gun, H2O	1	A, B
6	342279	• • SPRING, compression, 0.75 x 0.72 x 0.06 in., stainless steel	1	A
7	702118	• • NUT, lock, #10–32, upper	1	A, B
8	138737	• • PISTON, H20/A7A H.P. assembly	1	A, B
8A	-----	• • • NUT, seal, lock	1	A, B
8B	940090	• • • O-RING, Viton, 0.208 ID x 0.070 in. wide, brown	1	A, B
8C	-----	• • • PISTON	1	A, B
9	940157	• • O-RING, Viton, black, 0.562 x 0.688 in.	1	A, B
10	-----	• • BODY, gun	1	A
11	1039171	• • CARTRIDGE, packing, protective coating	1	A
11A	940134	• • • O-RING, Viton, 0.438 x 0.563 x 0.063 in.	1	A
12	-----	• • BALL TIP and seat	1	A, C
12A	-----	• • • BALL TIP	1	A, C
12B	940174	• • • O-RING, Viton, black, 0.688 x 0.813 in.	1	A, B, C
12C	-----	• • • SEAT	1	A, C
13	1051598	• • SCREW, flat head, socket, #10–32 x 0.625 in., 17–4 stainless steel	4	A
14	152496	• • NUT, retaining	1	A
15	981847	• SCREW, socket, 10–32 x 1.625, zinc	4	A
16	940105	• O-RING, PTFE, 0.25 x 0.375 x 0.06 in.	3	A, B
17	1054583	• MANIFOLD, A7A	1	
18	981405	• SCREW, square, set, $\frac{3}{8}$ –16 x 0.750 in., cup, zinc	1	
19	972029	• CONNECTOR, male, 37, $\frac{1}{2}$ –20 x $\frac{1}{4}$ in. NPT, stainless steel	2	
20	972716	• CONNECTOR, male, $\frac{1}{4}$ in. tube x $\frac{1}{8}$ in. NPT	1	
NS	247646	• CARD, medical alert, injection	1	A
NS	152999	• WRENCH	1	A
NS	901905	• BRUSH	1	A
NS	901911	• WRENCH, adjustment, module	1	A

NOTE A: To replace order 1056459 Service Kit, Module, A7A, SS, LBS.

B: Included in 1072408 Service Kit, Rebuild, Modular A7A Guns.

C: Included in 320031 Kit, Ball and Seat, Nickel.

NS: Not Shown

SERVICE NOTES:

- ① Apply VC-3 thread-locking compound to threads before installing ball tip.
- ② Apply VC-3 thread-locking compound to threads before tightening.
- ③ Apply pipe thread adhesive/sealant (Loctite High Temp SS567 or equivalent) to threads before installing.

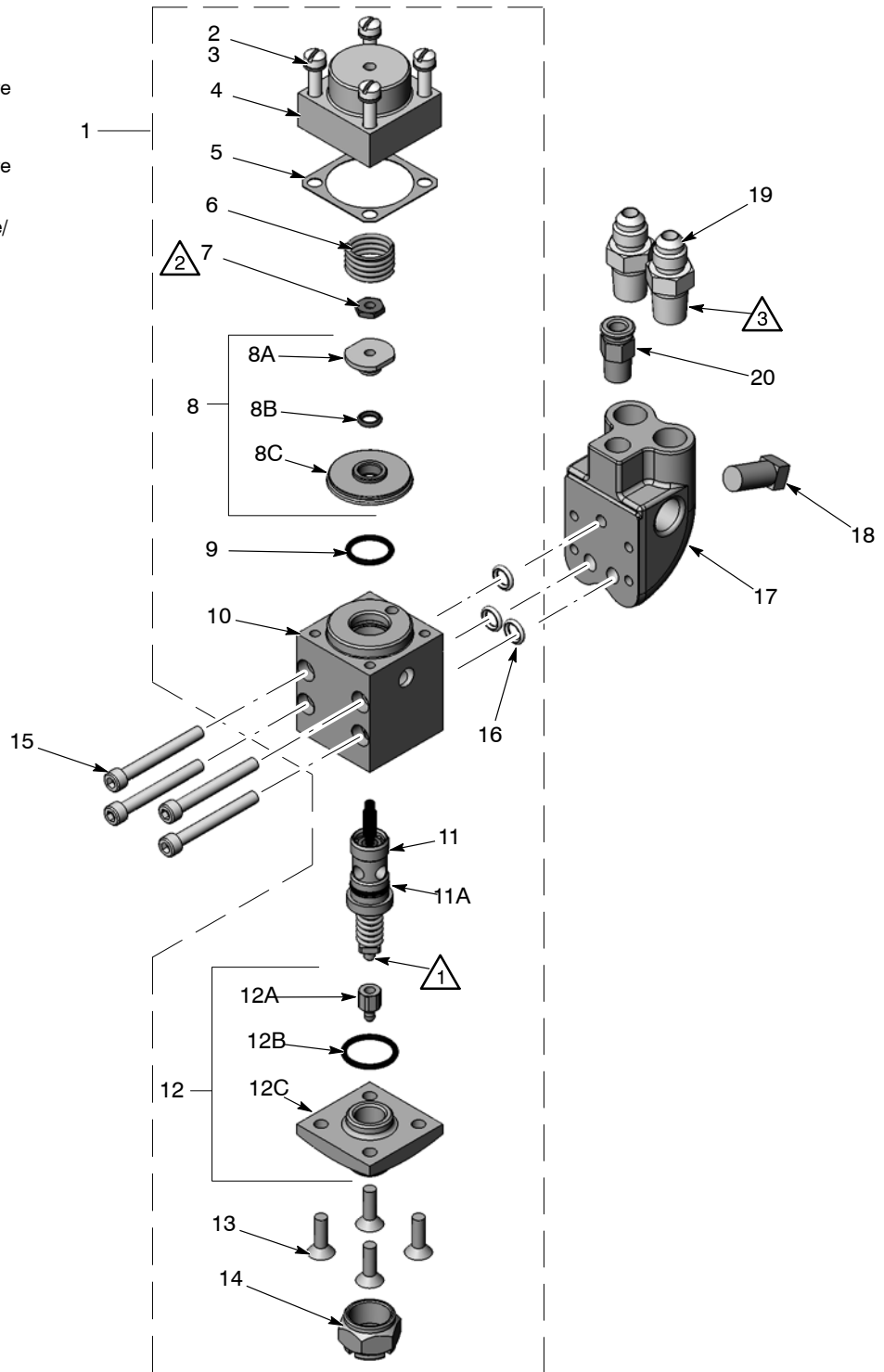

Figure 6 Single Gun Parts

Dual Gun Parts

Item	Part	Description	Quantity	Note
—	1059500	GUN, A7A, dual, stainless steel, LBS, with manifold	1	
1	-----	• MODULE, A7A, dual, stainless steel, Large Ball and Seat	1	A
2	981140	• • SCREW, fillet head, #10-32 x 1.00 in., slotted, zinc	8	A
3	983120	• • WASHER, lock, split, #10, steel, nickel	8	A
4	-----	• • CYLINDER, air	2	A
5	153031	• • GASKET, gun, H2O	2	A, B
6	342279	• • SPRING, compression, 0.75 x 0.72 x 0.06 in., stainless steel	2	A
7	702118	• • NUT, lock, #10-32, upper	2	A, B
8	138737	• • PISTON, H2O/A7A H.P. assembly	2	A, B
8A	-----	• • • NUT, seal, lock	2	A, B
8B	940090	• • • O-RING, Viton, 0.208 ID x 0.070 in. wide, brown	2	A, B
8C	-----	• • • PISTON	2	A, B
9	940157	• • O-RING, Viton, black, 0.562 x 0.688 in.	2	A, B
10	-----	• • BODY, gun	2	A
11	1039171	• • CARTRIDGE, packing, protective coating	2	A
11A	940134	• • • O-RING, Viton, 0.438 x 0.563 x 0.063 in.	1	A
12	-----	• • BALL TIP and seat	2	A, D
12A	-----	• • • BALL TIP	1	D
12B	-----	• • • SEAT	1	D
13	940174	• • O-RING, Viton, black, 0.688 x 0.813 in.	2	A, B
14	134975	• • RETAINER, seat, A7A	2	A
15	940105	• • O-RING, PTFE, 0.250 x 0.375 x 0.06 in.	2	A, B
16	-----	• • MANIFOLD, A7A dual, assembly	1	A
17	248932	• • • PLUG	2	A
18	900013	• • • BALL, 440 stainless steel, 0.125 in., 100	2	A
19	338693	• • SCREW, socket, #10-32 x 1.25 in., stainless steel	4	A
20	152496	• • NUT, retaining	1	A
21	981847	• SCREW, socket, 10-32 x 1.625, zinc	8	A
22	940105	• O-RING, PTFE, 0.25 x 0.375 x 0.06 in.	6	A, B
23	1054583	• MANIFOLD, A7A	2	
24	981405	• SCREW, square, set, $\frac{3}{8}$ -16 x 0.750 in., cup, zinc	2	
25	972029	• CONNECTOR, male, 37, $\frac{1}{2}$ -20 x $\frac{1}{4}$ in. NPT, stainless steel	4	
26	972716	• CONNECTOR, male, $\frac{1}{4}$ in. tube x $\frac{1}{8}$ in. NPT	2	
27	331475	• PIN, dowel, 0.250 x 0.625 in., H & G	1	C
NS	247646	• CARD, medical alert, injection	1	A
NS	152999	• WRENCH	1	A
NS	901905	• BRUSH	1	A
NS	901911	• WRENCH, adjustment, module	1	A

NOTE A: To replace order 1059498 Service Kit, Gun, A7A, Dual, SS, LBS.

B: Included in 1072408 Service Kit, Rebuild, Modular A7A Guns.

C: Dowel pin fits into holes in sides of manifolds and joins them together.

D: To replace the ball and seat, order kit 337305.

NS: Not Shown

SERVICE NOTES:

- 1 Apply VC-3 thread-locking compound to threads before installing ball tip.
- 2 Apply VC-3 thread-locking compound to threads before tightening.
- 3 Apply pipe thread adhesive/sealant (Loctite High Temp SS567 or equivalent) to threads before installing.

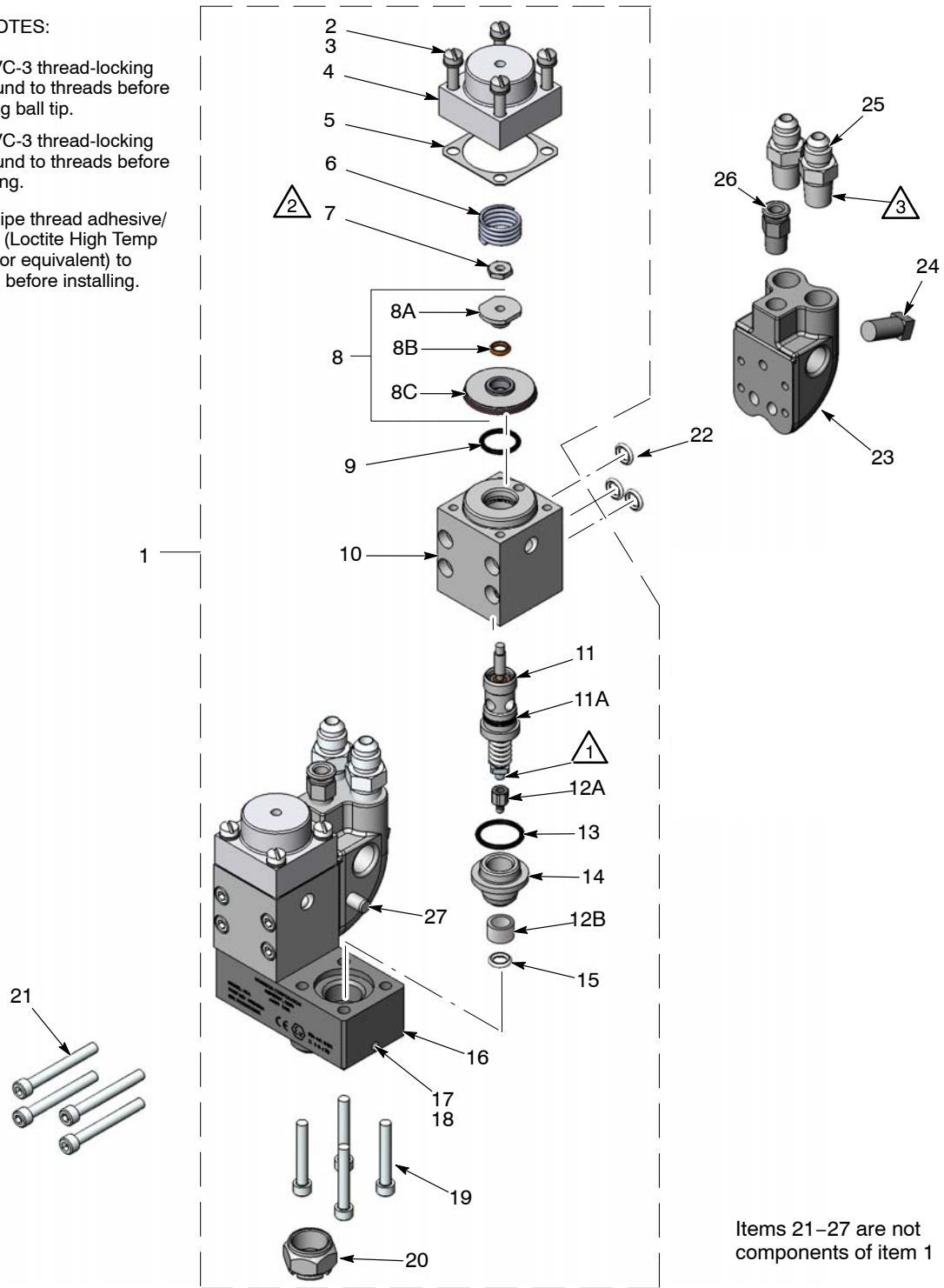

Items 21–27 are not components of item 1

Figure 7 Dual Gun Parts

Options

Part	Description	Note
159146	Mounting bar, gun, universal 46-cm (18-in.)	
901262	Quick exhaust valve	
973000	Nipple, steel, schedule 40, 1/8 in. NPT, 0.75 in. long	A
NOTE A: Use to install quick-exhaust valve.		

Service Kits

Part	Description	Note
1072408	SERVICE KIT, Rebuild, Modular A7A Guns	A
320031	KIT, Ball and Seat, Nickel	B
NOTE A: Order two kits to rebuild a dual gun. B: Used on single gun only.		

Service Parts

Part	Description	Note
900424	COMPOUND, thread lock, VC-3	
900481	ADHESIVE, pipe thread/hydraulic sealant	

DECLARATION of CONFORMITY

PRODUCT: A7A Modular Automatic Airless Spray Applicator

Models: Single and Dual Valves

Description: This is an air-operated airless high-pressure spray applicator.

Applicable Directives:

2006/42/EC – Machinery Directive

94/9/EC – ATEX Directive

Standards Used for Compliance:

EN/ISO12100 (2010)

EN13463-1 (2009)

EN13463-5 (2001)

Principles:

This product has been manufactured according to good engineering practice.
The product specified conforms to the directive and standards described above.

Flammable Atmosphere Marking: Ex II G c T6

Tech File: Notified Body #0518, Sira, UK

DNV ISO9001

ATEX Quality Notification – Baseefa (2001) Ltd (UK)



Date: 07 December 2012

Justin Hall
Engineering Manager
Industrial Coating Systems

Nordson Authorized Representative in the EU

Person authorized to compile the relevant technical documentation.

Contact: Operations Manager
Industrial Coating Systems
Nordson Deutschland GmbH
Heinrich-Hertz-StraBe 42-44
D-40699 Erkrath



A7A Modular Spray Guns

Service Kits and Parts Single Gun

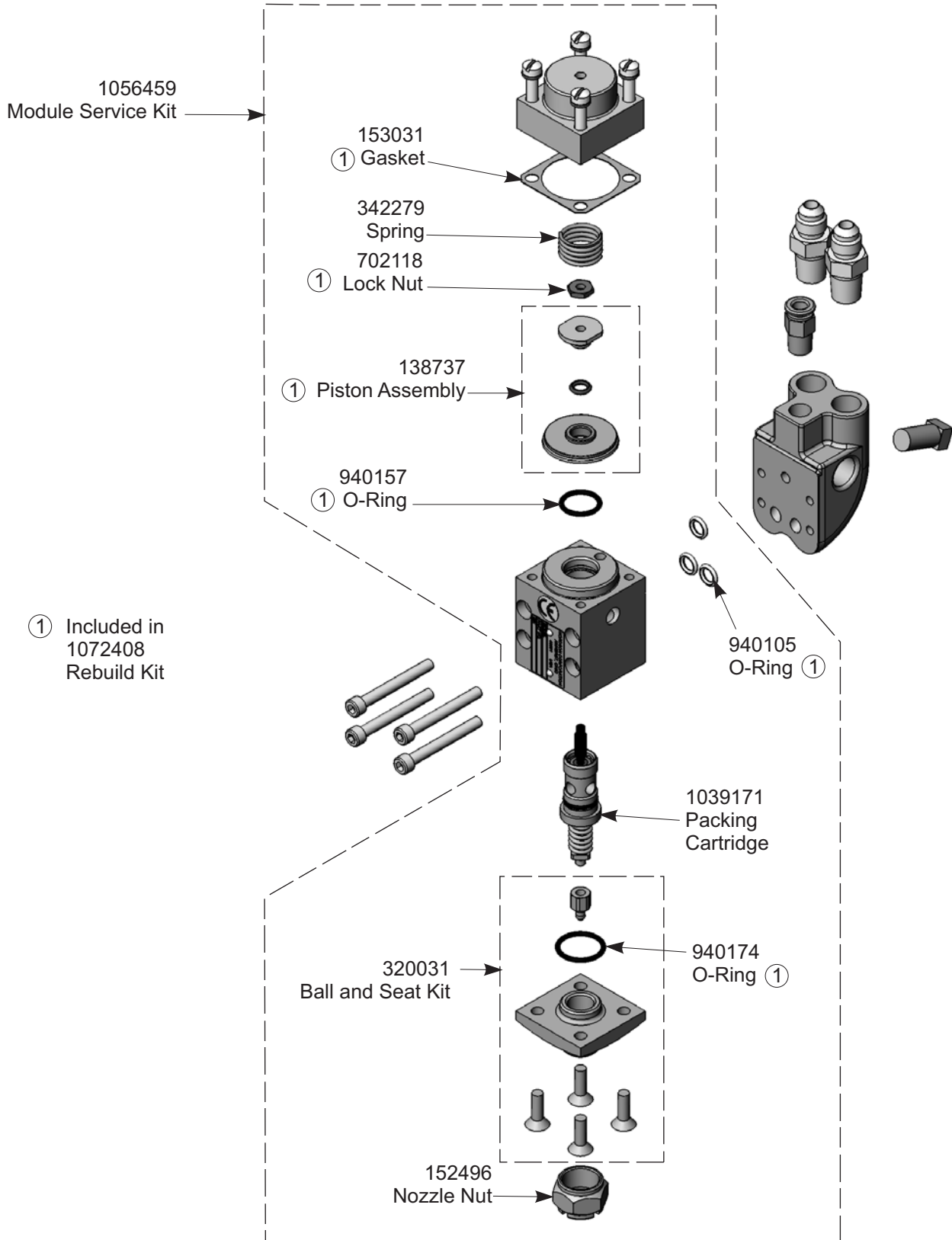

A7A Modular Spray Guns

Service Kits and Parts Dual Guns

1059498
Module Service Kit

① Included in
1072408
Rebuild Kit

